

# Mark 934 Series

## Ultra Capacity Sanitary Steam Trap System

**NEW!**

The Mark 934 sanitary steam trap system is specifically designed to facilitate the sterilization of sanitary vessels including fermentors, bioreactors and autoclaves without the addition of a SIP Heat up bypass loop. The system consists of a high flow sanitary steam trap and a standard capacity sanitary trap in the same body. The combined condensate capacity of the two traps handles the highest condensate and air flows during initial heat up, replacing the need for a bypass loop. The standard integral trap manages the lower rate of condensate production during the SIP temperature maintenance period.

### SIP HEAT UP

During clean steam start up, both bellows assemblies are fully open allowing quick discharge of non-condensable gases and cool condensate. The increasing temperature of the condensate causes the bellows elements to expand, moving each plug closer to its respective orifice, moderating the flow in accordance with the rate of condensate production.

The Mark 934 has enough capacity (21,900 lbs/hr (9934 kg/hr) to efficiently handle air and condensate heat up loads associated with bioreactors and fermenters.

### TEMPERATURE MAINTENANCE

As the sterilization temperature is achieved, the high flow sanitary bellows assembly shuts off, allowing the standard sanitary bellows assembly to provide close control and minimum subcooling (less condensate backup) at sterilization temperatures.

### VALUE PROPOSITION

- **Significant Capital Expense savings:** Elimination of automated three way bypass valves and tubing components, I/O costs and bypass installation labor
- **Utility Cost reduction:** less clean steam is required to accomplish heat up. The elimination of the bypass loop allows heat up to occur with less energy loss than conventional bypass arrangements as no steam is lost, only condensate
- **Plant availability increase:** Reduces heat up time and SIP total cycle time by maximizing steam efficiency and minimizing the probability of temperature faults during temperature maintenance



The Mark 934 is designed to operate up to a maximum differential pressure of 50 psig (3,4 bar) and will control condensate subcooling to less than 5°F, over a range from 10 to 50 psig.

### Features

- Readily handles the largest SIP loads
- Thermostatic steam trap body and stem in ASTM A479 316L
- Polished components-body interior and exterior mechanically polished to SF1, 20 Ra  $\mu\text{m}$  (0,51 Ra  $\mu\text{m}$ )
- Self-draining, no hold up
- Ease of disassembly and maintenance
- Sanitary clamp ends standard, other ends (tube weld), threaded, ISO/DIN available upon request
- Highest condensate flow rates in the industry
- Precise control of temperature at sterilization conditions
- FDA, USP Class VI gaskets standard

Sanitary Valves

Mark 934 Ultra Capacity Sanitary Steam Trap System



**STERIFLOW™ by Jordan Valve**  
3170 Wasson Road • Cincinnati, Ohio 45209  
Telephone 513.533.5600 • Fax 513.871.0105  
Toll-Free Telephone: 800.543.7311  
steriflow@richardsind.com • www.steriflowvalve.com

**SPECIFICATIONS**

Sizes: 1" (DN25), 1-1/2" (DN40), 2" (DN50)

**End Connections**

- Standard – Sanitary clamp ends (Tri-Clover™)
- Optional – Tube weld ends, DIN/ISO, threaded

**Material**

- Body Inlet/Outlet: 316L Stainless Steel
- Thermal Element: 316L Stainless Steel
- Gasket: Viton, Teflon Encapsulated (FDA, USP Class VI approved) (standard)
- Clamp: 304 SST

**Maximum Operating Conditions**

- Maximum Operating Pressure (PMO): 50 psig (3,4 bar)
- Maximum Allowable Temperature (TMA): 350°F (177°C)

**Design Pressure/Temperature Rating**

- Maximum Allowable Pressure (PMA): 145 psig (10,0 bar)
- Maximum Allowable Temperature (TMA): 350°F (177°C)

**Maximum Recommended Differential Pressure**

- 10 – 50 psig (0,68 bar – 3,4 bar)

**Maximum Recommended Vessel Size**

- For SIP drainage application on vessels up to 15,000L. Contact factory for application on larger size vessels

Weight: 12.25 lbs (5,6 kgs)

CRN #: 13987.5

**FLOW CAPACITY TABLE**

Subcooling: Number of ° F Condensate temperature below saturation	Capacity at Differential Pressure PSI-D (Bar-d)			
	10 (0,69)	20 (1,38)	30 (2,07)	50 (3,45)
5°F lbs/hr (kgs/hr)	220 (100)	400 (200)	560 (254)	890 (404)
10°F lbs/hr (kgs/hr)	2900 (1315)	4180 (1896)	5450 (2472)	7390 (3352)
20°F lbs/hr (kgs/hr)	5220 (2368)	7200 (3266)	8790 (3987)	11700 (5307)
Cold Water lbs/hr (kgs/hr)	9040 (4100)	12760 (5787)	16020 (7267)	21900 (9934)

**Applications**

- Typical applications are sterilization of high capacity fermentors, bioreactors, autoclaves and processing vessels
- High volume condensate drainage applications
- Condensate drainage from high volume process systems using clean steam

**DIMENSIONS**

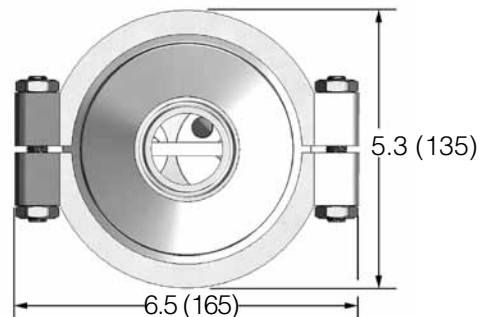
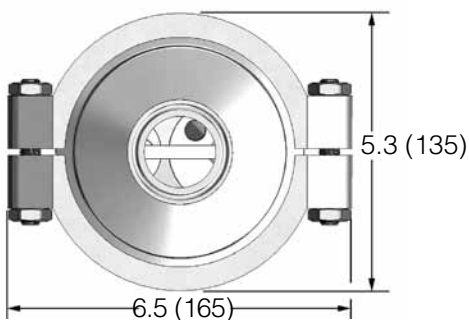
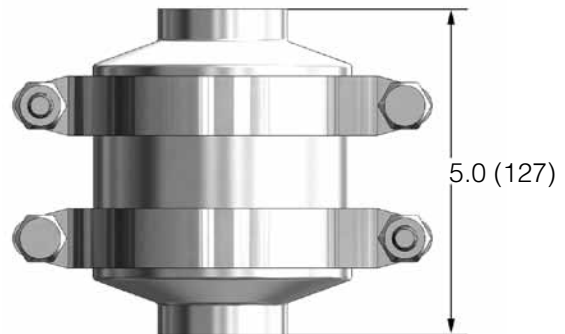
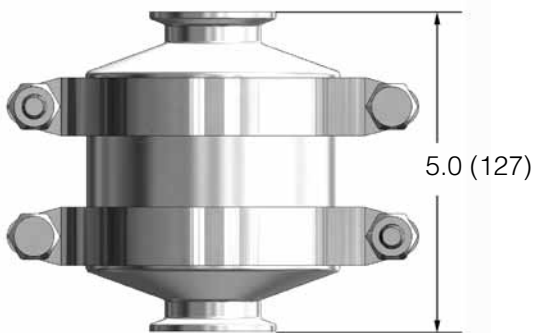

## FEATURES & BENEFITS

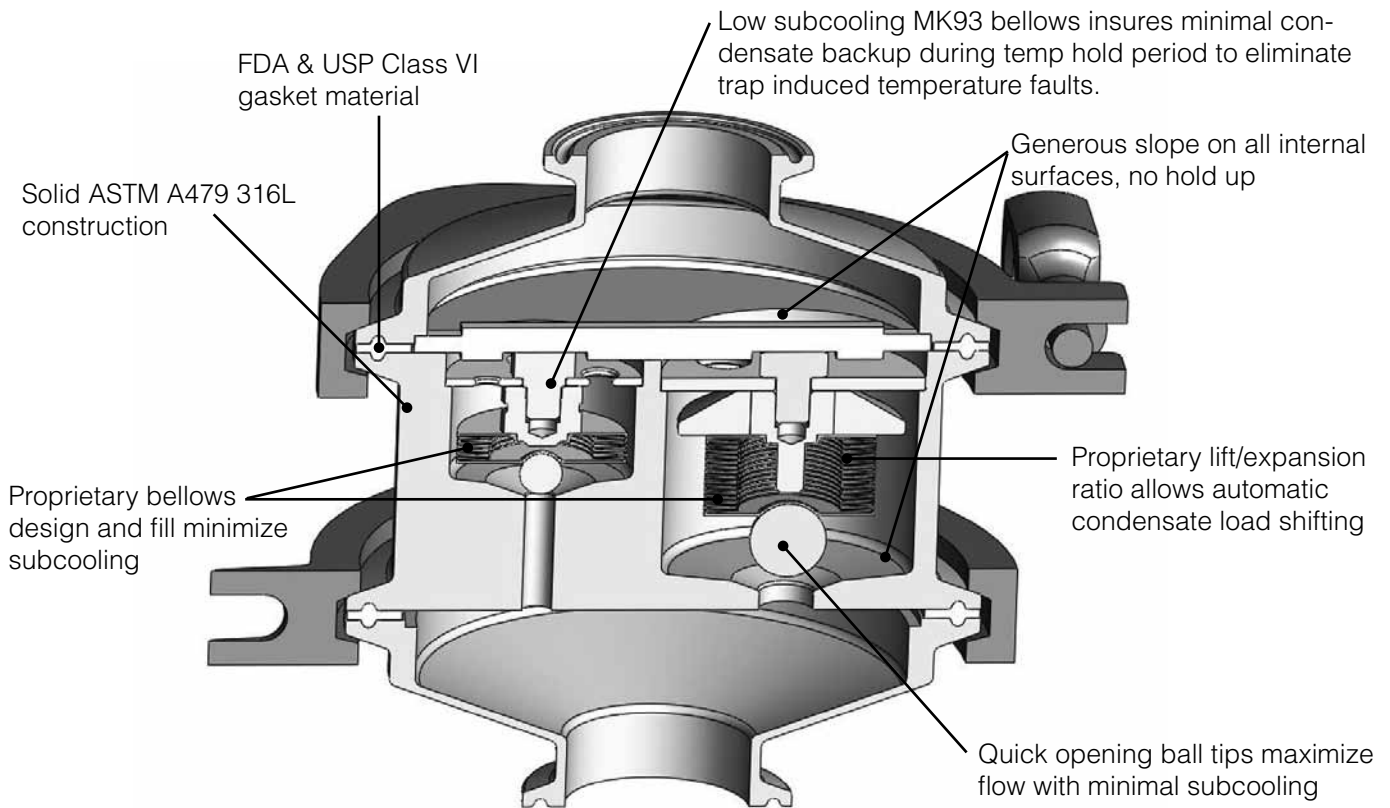

## INSTALLATION



### Conventional tubing arrangement using bypass loop for heavy, heat-up condensate load

During Heat-up, air, condensate and some live steam are directed to drain. At 98 C, the bypass valve opens and temperature maintenance condensate load is diverted through the steam trap.



### Installed savings of more than \$2000 using the MK934 to handle heat-up and maintenance loads

- **CAPex Reduction:** elimination of Capital cost of bypass tubing, valve, labor, I/O costs.
- **Utility Cost Reduction.** Less steam waste during Heat-up
- **Plant Availability Increase:** Increases bioreactor or fermentor availability by reducing Heat-up time, and SIP total cycle time

## MK934 COMBINATION SANITARY STEAM TRAP SYSTEM

## SPECIFICATION

Ultra capacity, multiple balanced pressure element, sanitary steam trap for handling SIP heat-up and temperature maintenance air, and condensate loads without bypass. Cold condensate capacity up to 21,900 lbs/hour. Temperature hold subcooling shall be no more than 3° F (1,6° C). Materials, surface finish, marking and documentation to be compliant with ASME BPE 2009; Body and bar components manufactured from ASTM A479 316L. Tri-clamp® body gaskets compliant with FDA 21 CFR part 177 and USP <88> Class VI, Wetted surface finish is SF1, mechanically polished to 20 Ra µin (0,51 Ra µm).

## ORDERING SCHEMATIC

Model	—	Size	—	End Connections	—	Special Options
934	—	150	—	C	—	0

1	Model
934	Standard

2	Size
100	1" DN25
150	1-1/2" DN40
200	2" DN50

3	End Connections
Inlet & Outlet	
C	Inch Tri-Clamp Vertical Inlet/Outlet
S	ISO Tri-Clamp Vertical Inlet/Outlet
D	DIN Tri-Clamp Vertical Inlet/Outlet
T	Inch Tube Vertical Inlet/Outlet
M	Metric Tube Vertical Inlet/Outlet
Z	Non Standard

4	Special Options
S	Silverback Gasket (FDA & USP Class VI)
Z	Non-Standard

Note: TFE/Viton gasket is standard

*Steriflow Valve reserves the right to make revisions to its products, specifications, literature, and related information without notice. Please visit our website at [www.steriflowvalve.com](http://www.steriflowvalve.com) for the latest information on our products.*